

We offer the widest range of high-speed and high-resolution digitizers available on the market today. Our powerful PC-based instrumentation products allow you to create reliable, flexible and high-performance solutions quickly and easily.

Reduce development time and costs for testing complex applications such as radar, wireless communications, spectroscopy, etc. by using our GageScope software or SDKs.

APPLICATIONS

Non-destructive testing
Military & Aerospace
Communications & Wireless
Radar, Lidar
High energy physics
Embedded digitizer

CompuScope 14100

Ultra-Fast Waveform Digitizer Card for PCI Bus

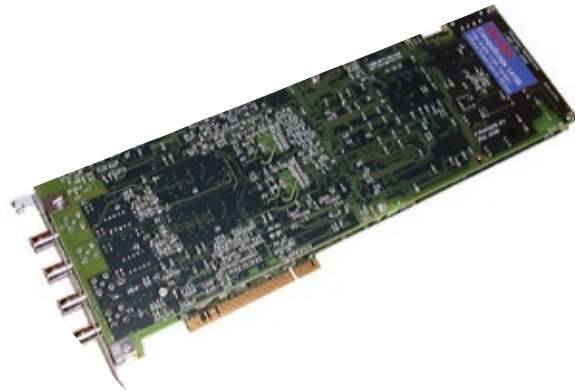

General-purpose digitizer module for high-accuracy synthetic instrumentation, automated test systems, and scientific research.

FEATURES

- 14 bit, 100 MS/s A/D
- Up to 100 MHz bandwidth
- Up to 8 MegaSamples of on-board acquisition memory
- 63 dB signal to noise ratio
- Multi-card systems of up to 8 channels at 100 MS/s (16 channels at 50 MS/s)
- Fast data transfer rate to PC memory
- Programming-free operation with GageScope® oscilloscope software
- Software Development Kits available for LabVIEW, MATLAB, C/C#

CompuScope 14100 Simplified Block Diagram

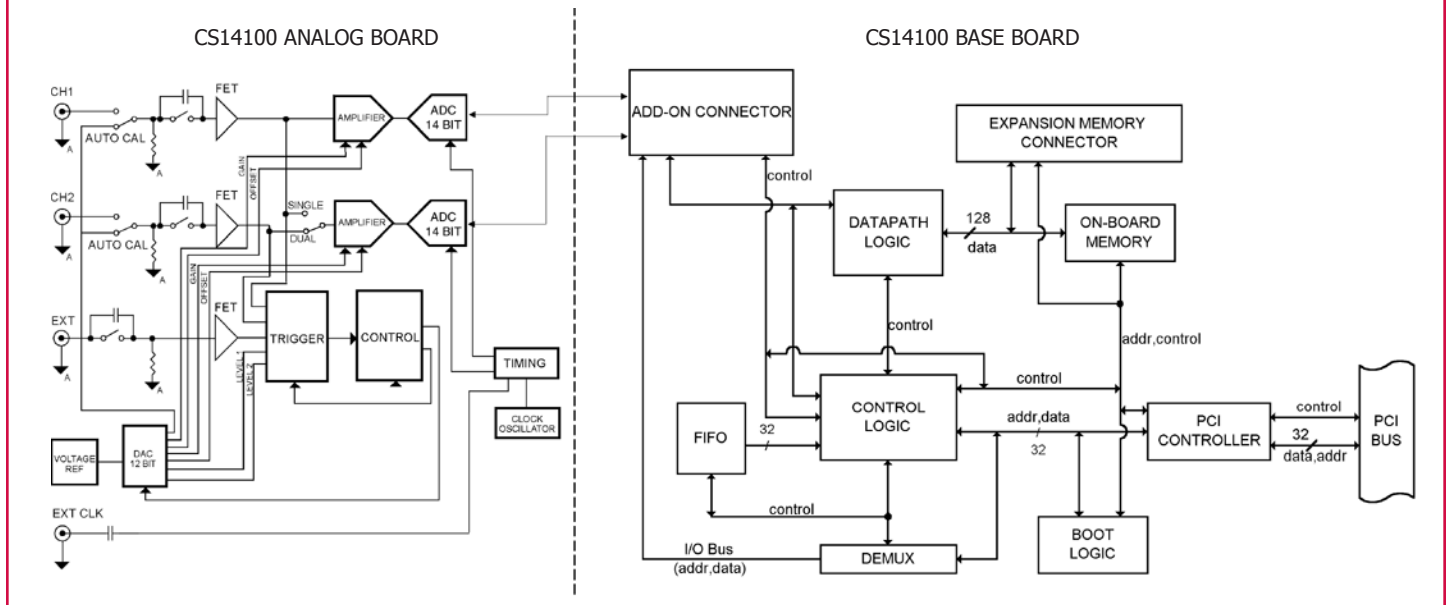

COMPUSCOPE 14100

CompuScope 14100 samples analog signals at speeds up to 100 MS/s with 14-bit resolution and stores the data in on-board memory.

100 MS/S SAMPLING

CompuScope 14100 uses two monolithic sub-ranging A/D converters, each running at 50 MS/s, to provide a dual-channel simultaneous real-time sampling rate of 50 MS/s.

In the single-channel mode the two ADCs are clocked in a "ping-pong" mode to achieve up to 100 MS/s sampling. An on-board crystal-controlled timing circuit ensures timebase accuracy and long-term thermal stability.

The on-board auto-calibration circuitry allows the two channels to be matched in order to reduce the image signal.

HIGH IMMUNITY TO DIGITAL NOISE

In order to isolate the high-frequency analog circuitry from PCI bus-related digital electronics, a two-board piggy-back configuration is used. This allows maximum separation of analog and digital grounds, thereby providing high immunity to digital noise.

MEMORY DEPTH

CompuScope 14100 is available with memory depths of 1M and 8M (14-bit samples). This memory can be used as a circular buffer for storage of pre- and post-trigger data.

In the single-channel mode, the maximum number of sample points is equal to the memory depth of the CompuScope 14100 model being used, whereas in the dual-channel mode the maximum number of sample points is half the memory depth.

The data stored in the CompuScope 14100 memory can be transferred to the system RAM for post-processing, display or storage to hard disk without any interface bus (no GPIB bus required).

FAST BUS THROUGHPUT

The high-speed, 32 bit, bus-mastering interface to the PCI bus allows the data from the on-board memory of the CompuScope 14100 to be transferred to the system RAM, or any other PCI destination, at sustained

rates of up to 80 MB/s under single-tasking operating systems. Under Windows, this rate depends on the architecture of the user application. Under controlled conditions, it is still possible to achieve 80 MB/s recording speed to the system RAM.

BUS MASTERING

CompuScope 14100 is fully capable of becoming a PCI bus master in order to transfer data at the maximum rate of 80 MB/s.

A PCI bus Master is a card which can take control of the bus and transfer data to any PCI target device such as system RAM without any involvement from the CPU.

FLEXIBLE TRIGGERING

CompuScope 14100 features state-of-the-art analog triggering. An analog comparator provides triggering from either one of the input channels, or from an external signal or from software.

In addition to the trigger source, trigger level and slope are also selectable by software, making the trigger system similar to traditional oscilloscopes.

EXTERNAL CLOCK

An external clock input is included as standard on the CS14100 as a BNC input for situations where a special sampling frequency is required.

In both single-channel and dual-channel mode, input signals are sampled at every rising edge of the External Clock.

This External Clocking scheme is a marked improvement over the options available for previous CompuScope models.

The External Clock must be a sine wave with a minimum amplitude of 1 Volt RMS and a maximum amplitude of 2 Volts RMS.

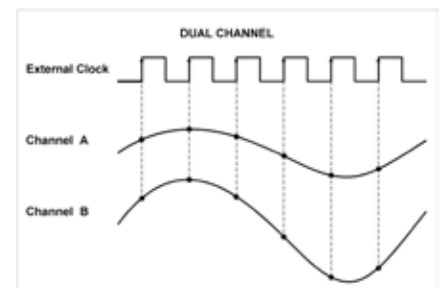

The allowed external clock range is 40 to 100 MHz for single channel mode or 20 to 50 MHz for dual channel mode

The duty cycle of the External Clock signal must be 50% ±30% for single channel mode and 50% ±5% for dual channel mode.

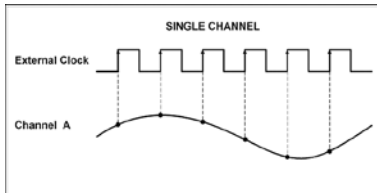

MULTIPLE RECORD

Even though the PCI bus allows very fast data throughput to system RAM, there may still be applications in which data bursts cannot be off-loaded either because of very fast trigger repeat frequency or because of software limitations.

Multiple Recording allows CS14100 to capture data on successive triggers and stack it in the on-board memory. Up to 4,194,304 triggers can be captured in Multiple Record mode.

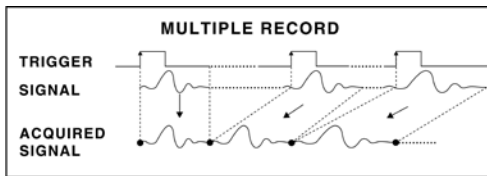

It should be noted that only post-trigger data can be captured in Multiple Record Mode.

GageScope Software can display the stacked data as individual acquisitions. Software drivers also provide support for accessing Multiple Record data.

Once the CS14100 has finished capturing a Multiple Record segment, the trigger circuitry is automatically re-armed within 18 (9) sample clock cycles in single (dual) channel mode, to start looking for the next trigger. No software intervention is required.

Multiple Recording is useful for applications where a series of bursts of data have to be captured in quick succession and there is not enough time to off-load the data to system RAM.

Another situation may be when data storage has to be optimized. These are cases in which only certain portions of the incoming signal are of interest and data capture during the dead-time between successive portions is not useful.

Examples of these situations are radar pulses, ultrasound data, lightning pulses, imaging signals and explosion testing..

MULTI-CARD SYSTEMS

One of the most unique features of the CompuScope cards is the Multi-Card system that can be configured.

A Multi-Card system, comprised of one Master and up to 7 Slave CS14100 boards, can be ordered from the factory if the user wants to capture more than two channels with a common clock and trigger. A board-to-board interconnect is supplied with the system. This interconnect carries all the signals needed for proper synchronization.

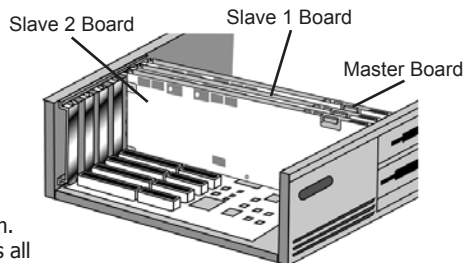

The following Master/Slave systems can be configured.

- For 1M Memory Models: 2, 4, 6 or 8 cards can be configured
- For 4M & 8M Memory Models: 2, 3 or 4 cards can be configured

GageScope can then display all channels from these boards on the same screen. Software drivers also support such Master/Slave systems.

100 MHZ BANDWIDTH VERSION OF CS141000

A version of the CS14100 is available with 100 MHz enhanced bandwidth.

With 100 MHz bandwidth, the CS14100 widens the precision and range of applications of fast, high-resolution digitizers. The enhanced bandwidth minimizes the distortion of higher frequency components, improving the characterization of fast pulses from radar signal and high-speed electronic circuitry. While sampling at 100 MS/s, the new CS14100-100MHz allows undersampling, all the way up to the Nyquist frequency, of continuous periodic signals to extract important spectral information.

A better frequency response also enables more reliable I&Q measurements in communication systems. The CS14100 is the tool of choice for your critical test and measurements applications.

To allow higher frequencies through, including noise, some of the standard CS14100 specifications are affected when purchasing the 100 MHz bandwidth version. Please see the detailed specifications below for more information.

Bandwidth (Typical): 120 MHz
Bandwidth (Guaranteed): 100 MHz

Typical Dynamic Parameters: Measured at specified input at 100 MS/s / 50 MS/s (Single / Dual)

	Single Channel Mode		Dual Channel Mode	
	15 MHz	75 MHz	15 MHz	75 MHz
SNR (dB)	41	48	56	52
SFDR (dB)	41	52	74	67
SINAD (dB)	41	47	55	51
THD (dB)	-63	-54	-63	-61
ENOB (bits)	6.5	7.8	9.0	8.3

SYSTEM REQUIREMENT

PCI-based computer with at least one free full-length PCI slot, 128 MB RAM, 50 MB hard disk and SVGA video.

SIZE

Memory Depth: Card occupies:
1M 1 full-length slot
8M 2 full-length slots

POWER (IN WATTS)

+5 V		
Memory	Worst case	Typical
1M	24.8	22.5
8M	30.3	27.5
+12 V		
	Worst case	Typical
All Memory Models	1.7	1.5
-12 V		
	Worst case	Typical
All Memory Models	0.6	0.5

Note: Y-cable must be connected to auxiliary power connector if more than one CS14100 card is installed



CHANNELS A & B

Inputs per card:	2
Impedance:	1 M Ω 40 pF or 50 Ω ; software-selectable
Coupling:	AC or DC
Resolution:	14 bits
Bandwidth:	
DC coupled:	DC to 50 MHz
AC coupled:	10 Hz to 50 MHz
Input Voltage Ranges:	± 100 mV, ± 200 mV, ± 500 mV, 1 V, ± 2 V, ± 5 V
Absolute Maximum Amplitude:	
1 M Ω Impedance:	± 15 V (continuous)
50 Ω Impedance:	± 5 V (continuous)
DC Accuracy relative to full scale input:	

Input Range	Accuracy
± 5 V, ± 2 V, ± 1 V	0.5%
± 500 mV	0.5%
± 200 mV	1%
± 100 mV	2%

Sampling Rate

Single-channel Mode (Channel A only):

MS/s:	100, 50, 25, 10, 5, 2, 1
kS/s:	500, 200, 100, 50, 20, 10, 5, 2, 1

Dual-channel Mode (Channel A and B simultaneously):

MS/s:	50, 25, 10, 5, 2, 1
kS/s:	500, 200, 100, 50, 20, 10, 5, 2, 1

Protection:

1 M Ω Impedance:	Diode Clamped
50 Ω Impedance:	No Protection

Connector:

BNC

† DYNAMIC PARAMETERS

Measured using 1 MHz sine wave input at 50 MS/s, dual channel mode with amplitude of 95% of full scale on the ± 1 V range. Typical values listed

SNR:	63 dB
SFDR:	70 dB
SINAD:	60 dB
THD:	-72 dB
ENOB:	10.2 bits

ACQUISITION MEMORY

Data Storage:	In on-board memory
Memory Sizes:	1M, 8M (14-bit samples)
Maximum Memory Depth:	
Single-Channel Mode:	Full on-board memory
Dual-Channel Mode:	Up to half on-board memory per channel

TRIGGERING

Number of Trigger Inputs:	2 per system
Trigger Source:	CH A, CH B, EXT, Software
Type:	Analog triggering
Sensitivity:	$\pm 10\%$ of full scale
Level Accuracy:	$\pm 5\%$ of full scale
Slope:	Positive or Negative; software-selectable
Post Trigger Data:	64 (128) points minimum. Can be defined with a 64 (128) point resolution in dual (single) channel mode

EXTERNAL TRIGGER

Impedance:	1 M Ω , 35 pF
Amplitude:	Absolute Max ± 15 V
Voltage Range:	± 1 V and ± 5 V
Bandwidth:	30 MHz

Coupling:	AC or DC
Connector:	BNC

INTERNAL CLOCK

Source:	100 MHz Clock Oscillator
Accuracy:	± 50 ppm (0 to 70° C)

EXTERNAL CLOCK

Maximum Frequency	100 MHz in single channel 50 MHz in dual channel
Minimum Frequency	40 MHz in single channel 20 MHz in dual channel
Signal Level:	MIN 1 V RMS MAX 2 V RMS
Termination Impedance:	50 Ω
Sampling Edge:	Rising
Required Duty Cycle:	50% $\pm 30\%$ in single channel 50% $\pm 5\%$ in dual channel
Coupling:	AC

MULTIPLE RECORD

Pre-trigger Data:	None
Record Length:	128 (256) points minimum. Can be defined with a 64 (128) point resolution in dual (single) channel mode
Maximum number of Triggers:	4,194,304

MULTI-CARD SYSTEMS

Operating Mode:	Master/Slave or Multiple Independent
Number of Cards in:	
Master/Slave Mode:	2, 4, 6 or 8 cards for 1M models 2, 3 or 4 cards for 4M models
Multiple Independent Mode:	Limited by backplane
Maximum Number of Channels in Master/Slave Mode:	16 at 50 MS/s (1M model) 8 at 100 MS/s (1M model)

MASTER/SLAVE SYSTEM TRIGGERING

Number of Trigger Inputs:	2 per system
Trigger Source:	CH 1, CH 2, EXT or Software (Master Card Only)
Sensitivity :	$\pm 10\%$ of full scale
Level Accuracy :	$\pm 5\%$ of full scale
Trigger Slope:	Positive or Negative; software-selectable

PCI BUS INTERFACE

Plug-&-Play:	Fully supported
Bus Width:	32 bits
Bus Speed:	33 MHz
Compatibility:	5 Volt PCI-compliant slot

OPERATING SYSTEMS SUPPORTED

Windows 98/ME/NT*	CompuScope Driver version 3.60.22
* Version 4, SP3 or higher	
Windows 2000**/XP	CompuScope Driver version 4.xx.xx
** SP1 or higher	

APPLICATION SOFTWARE

GageScope: Windows-based software for programming-free operation	
LITE Edition:	Included with purchase, provides basic functionality
Standard Edition:	Provides limited functionality of advanced analysis tools, except for Extended Math
Professional Edition:	Provides full functionality of all advanced analysis tools



SOFTWARE DEVELOPMENT KITS (SDK)

CompuScope SDK for C/C# for Windows*
CompuScope SDK for MATLAB for Windows
CompuScope SDK for LabVIEW for Windows

*C/C# SDK is compatible with LabWindows/CVI 7.0+ compiler.
Visual Basic.NET support available with purchase of C/C# SDK.

Contact your Gage Sales Agent for information on Linux support.

ELECTROMAGNETIC COMPATIBILITY

EC Council Directive 89/336/EEC



EN 61326 Class A

- IEC 61000-4-2 Electrostatic Discharge (Performance Criterion B)
- IEC 61000-4-3 RF Electromagnetic Field (Performance Criterion A)
- IEC 61000-4-4 Electrical Fast Transient/Burst (Performance Criterion B)
- IEC 61000-4-5 Power Surge (Performance Criterion B)
- IEC 61000-4-6 Conducted RF (Performance Criterion A)
- IEC 61000-4-11 Voltage Dips & Interruptions (Performance Criterion B)
- EN 61000-3-2 AC Power Line Harmonics Emissions

AS/NZS 2064

Australian emissions standard for Industrial, Scientific and Medical Equipment
Compliance demonstrated on a single card configuration

ENVIRONMENTAL

Operating Temperature: 5°C to 40°C
Relative Humidity: Less than 80%, non-condensing
Maximum Altitude: 2,000 meters

WARRANTY

One year parts and labor
Certificate of NIST Traceable Calibration is included.

All specifications subject to change without notice;
specifications are not guaranteed under all possible combinations of modes of operation.

†These specs differ slightly on the CS14100-100 MHz Bandwidth version. Please refer to the 100 MHz Bandwidth Version section on p.3 of this datasheet for specs on this model.

ORDERING INFORMATION

Hardware & Upgrades

CompuScope 14100-1M	141-001-002
CompuScope 14100-8M	141-001-003
CompuScope 14100-128M	141-001-004
CompuScope 14100-512M	141-001-005
CompuScope 14100-1G	141-001-006
CS14100 Memory Upgrades	Contact Factory
Master Multi-Card Upgrade	141-181-003
Slave Multi-Card Upgrade	141-181-004
CompuScope 14100-100MHz Option	141-001-100

GageScope Software

GageScope: Lite Edition	Included
GageScope: Standard Edition (with Purchase of CompuScope Hardware)	300-100-351
GageScope: Professional Edition (with Purchase of CompuScope Hardware)	300-100-354

Software Development Kits (SDKs)

Gage SDK Pack on CD	200-113-000
CompuScope SDK for C/C#	200-200-101
CompuScope SDK for MATLAB	200-200-102
CompuScope SDK for LabVIEW	200-200-103

All Upgrades performed at the factory.

900 N. State St.
Lockport, IL 60441-2200

Toll-Free (US and Canada):

phone 1-800-567-4243
fax 1-800-780-8411

Direct:

phone +1-514-633-7447
fax +1-514-633-0770

Email:

prodinfo@gage-applied.com

To find your local sales representative
or distributor or to learn more about
GaGe's products visit:

www.gage-applied.com

Updated April 3rd, 2006

Copyright © 2004, 2005, 2006 Gage Applied Technologies. All rights reserved.